

LET2 *Low Entry Tilt*

Power To Get the Job Done



Crane Carrier's LET2 is a work horse with sophisticated engineering and quality that's built to last. Rugged framework, durable cab construction and attention to detail makes this vehicle a good investment with an ergonomic cab environment that will keep your employees healthy and safe.

Check out all the great features we've packed into this vehicle:

- 18" step in height, both RH & LH sides
- Remote mounted radiator, 1814 Sq. Inches
- Increased interior space, small engine cover
- Increased visibility with large glass area
- Improved dash and instrumentation layout
- Tilt-telescoping steering column avail. both sides
- Overhead console with storage space
- Quiet & comfortable interior
- Bi-fold or solid doors, LH, RH or both sides
- Heavy duty front bumper standard
- Cummins ISL "G" available, up to 320 HP
- Cummins ISC 8.3, ISL9, & X11.9 available
- Enhanced maneuverability with tighter turn radius
- Central fluid check location - behind cab
- 2010 EPA Diesel emission installation, DPF/SCR
- 10 gallon DEF tank with convenient location
- Single Reyco spring, Ridewell tandem, Hendrickson single or tandem rear suspension available





Cab Tilt for Engine Access



Spacious Cab Interior



RH, LH or Dual Steering



10 Gal. DEF Tank



Remote Mounted Radiator



Large Door Opening

Additional Features and Benefits of the Crane Carrier LET2

- **Cummins** ISC8.3, or ISL 9, X11.9 Diesel available -up to 385 HP available
- **Engine Emissions** 50-State, Clean Idle, 2010 EPA Certified
- **Cummins Engine Protection** 30-second shutdown
- **Transmission** Allison 4th Generation, 3000 / 3500 RDS, 4000 / 4500 RDS
- **4th Generation Shifter** pushbutton w/ Oil Level, Filter, & Clutch condition monitors
- **Steering Column** Tilt / Telescopic w/ self-canceling turn signals
- **Steering Wheel** Black 18" soft touch, 2-spoke
- **ABS Brake System** Bendix, 4S/4M or 6S/6M with ATC optional
- **Cab Construction** 94" w x 54" d x 78" h, galvaneal steel
- **Cab Insulation** inside cab roof & back wall, outside cab bottom & engine cover
- **Doors** Solid w/ manual roll-down windows, lower view windows, galvaneal steel
- **Door Trim** Inner molded gray plastic panels w/ armrest & storage pocket
- **Mirrors** LH & RH side 15 x 8", w/ black steel brackets, C-loops & molded mirror heads
- **Cab Tilt System** RH manual hydraulic jack mounted behind cab
- **Chassis Wiring** Packard "GXL" color coded, loomed wiring, SAE J1939 configured
- **Mini-bus type electrical circuits** automatic reset breakers and relays
- **Plug-in connectors** & water resistant exterior connectors for body wiring
- **Lighting** (2) 5" x 8" halogen headlights, (7) ID & marker lights
- **2 LED turn signals** recessed in bumper
- **Dome Lights** Combination, interior map lights w/ selector switch

- **Seats** LH & RH bucket type, 2-way adjustable; black vinyl or cloth
- **Available Seat Options** air ride, lumbar support, arm and head rests
- **Safety Belts (2)** w/ 7" shoulder height adjustment
- **Sunvisors (2)** hinged vinyl full width w/ document keepers
- **Interior Trim** padded vinyl engine cover, upholstered head liner and back wall panels
- **HVAC** 31,600 BTU / HR at 100° F. 3-speed blower

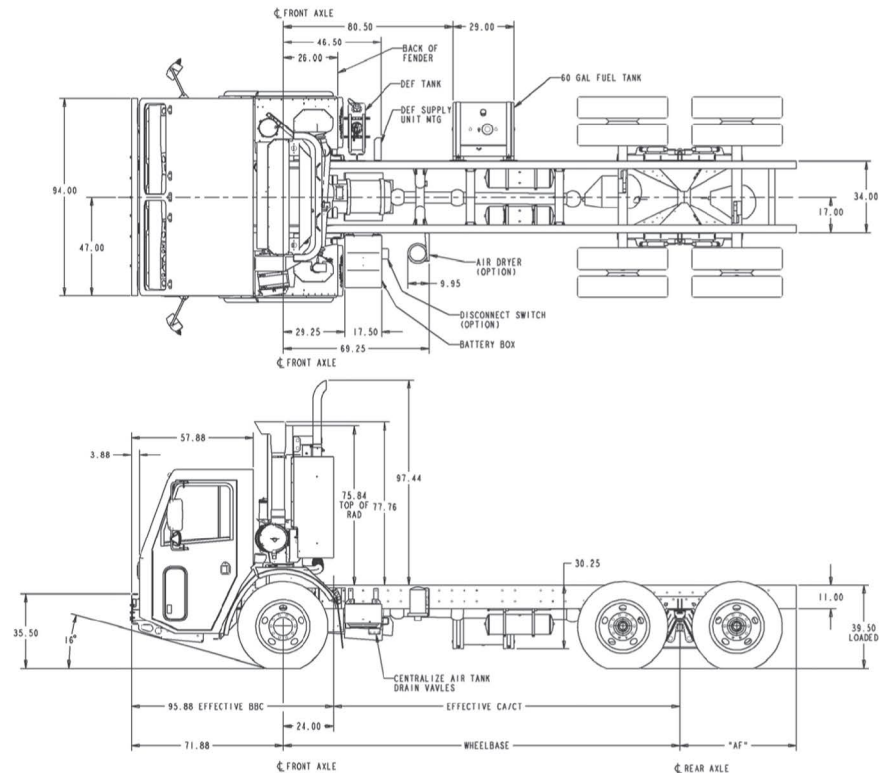

CRANE CARRIER COMPANY

LET2 *Crew Cab*

Power To Get the Job Done



Crane Carrier's LET2 Crew Cab is a work horse with sophisticated engineering and quality that's built to last. Rugged framework, durable cab construction and attention to detail makes this vehicle a good investment with an ergonomic cab environment that will keep your employees healthy and safe.

Check out all the great features we've packed into this vehicle:

- 18" step in height, both RH & LH sides
- Remote mounted radiator, 1814 Sq. Inches
- Increased interior space, small engine cover
- Increased visibility with large glass area
- Seating is available for up to four forward facing passengers
- Tilt-telescoping steering column avail. both sides
- Overhead console with storage space
- Quiet & comfortable interior
- Bi-fold or solid doors, LH, RH or both sides
- Heavy duty front bumper standard
- Cummins ISL "G" available, up to 320 HP
- Cummins ISC 8.3, ISL9, & X11.9 available
- Central fluid check location - behind cab
- 10 gallon DEF tank with convenient location
- Single Reyco spring, Ridewell tandem, Hendrickson single or tandem rear suspension available





Additional Features and Benefits of the **LET2 Crew Cab**

- **Engine Emissions** 50-State, Clean Idle, 2010 EPA Certified
- **Cummins Engine Protection** 30-second shutdown
- **Transmission** Allison 4th Generation, 3000 / 3500 RDS, 4000 / 4500 RDS
- **4th Generation Shifter** pushbutton w/ Oil Level, Filter, & Clutch condition monitors
- **Steering Column** Tilt / Telescopic w/ self-canceling turn signals
- **Steering Wheel** Black 18" soft touch, 2-spoke
- **ABS Brake System** Bendix, 4S/4M or 6S/6M with ATC optional
- **Cab Construction** 94" w x 69" d x 78" h, galvaneal steel
- **Powder coated steel dash housing** is standard for LH steer only.
- **Molded plastic dash housing** is standard with RH or Dual Steer
- **Cab Insulation** inside cab roof & back wall, outside cab bottom & engine cover
- **Doors** Solid w/ manual roll-down windows, lower view windows, galvaneal steel
- **Door Trim** Inner molded gray plastic panels w/ armrest & storage pocket
- **Mirrors** LH & RH side 15 x 8", w/ black steel brackets, C-loops & molded mirror heads
- **Cab Tilt System** RH electric hydraulic jack mounted behind cab
- **Chassis Wiring** Packard "GXL" color coded, loomed wiring, SAE J1939 configured
- **Mini-bus type electrical circuits** automatic reset breakers and relays
- **Plug-in connectors** & water resistant exterior connectors for body wiring
- **Lighting** (2) 5" x 8" halogen headlights, (7) ID & marker lights
- **2 LED turn signals** recessed in bumper
- **Dome Lights** Combination, interior map lights w/ selector switch

- **Seats** LH & RH bucket type, 2-way adjustable; black vinyl or cloth
- **Available Seat Options** air ride, lumbar support, arm and head rests
- **Safety Belts** (2) w/ 7" shoulder height adjustment
- **Sunvisors** (2) hinged vinyl full width w/ document keepers
- **Interior Trim** padded vinyl engine cover, upholstered head liner and back wall panels
- **HVAC** 31,600 BTU / HR at 100° F, 3-speed blower

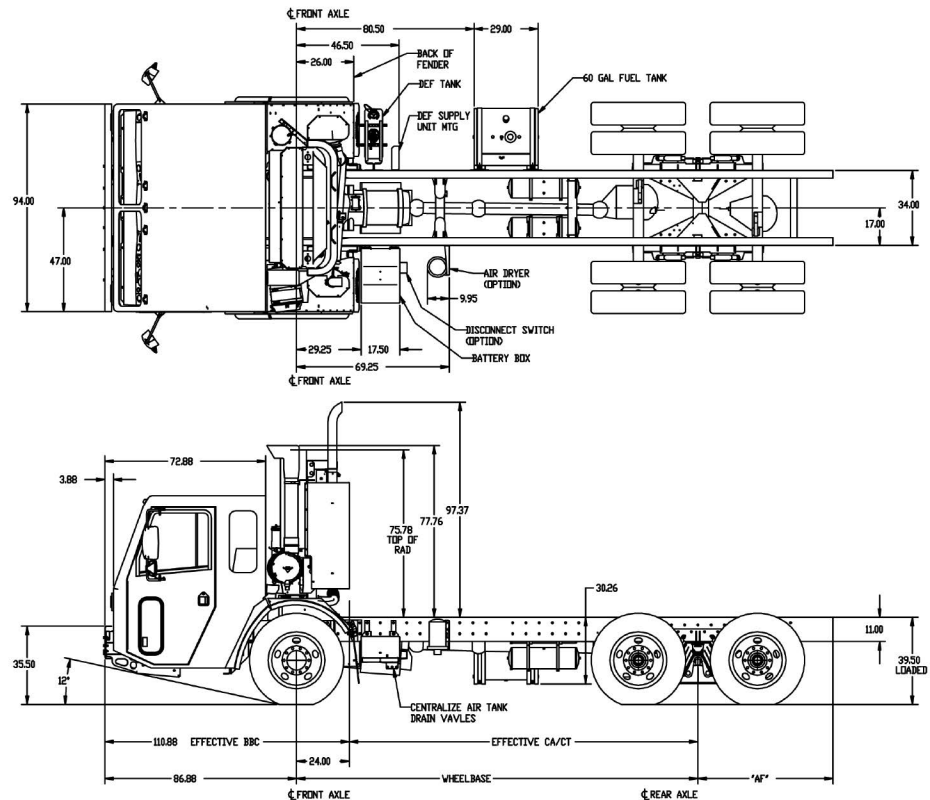

CRANE CARRIER COMPANY
The Refuse Vehicle Specialists