

TOUGHNESS AND DEPENDABILITY HAS NEVER BEEN SO VERSATILE.

The 47X expands the X-Series toolkit, offering a fast and easy upfit solution engineered to enhance safety, versatility and maneuverability, along with providing numerous lightweight options to make it ideal for applications where weight savings are critical.

DIMENSIONS

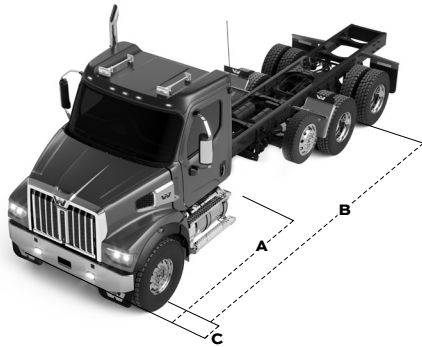

SF	SET FORWARD AXLE	A BBC: 111.6" (110.8" WITH SF BRIDGE FORMULA BUMPER MOUNTING)
		B WB: UP TO 415"
		C BA: 30.1"

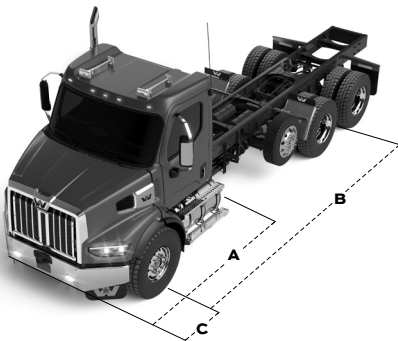

SB	SET BACK AXLE	A BBC: 111.6"
		B WB: UP TO 361"
		C BA: 46.5"

SLEEPER



36" Trench-style Low Roof
Available in 36" Mid Roof



48" Mid Roof

CAB

- X-Series steel-reinforced aluminum cab with X-Series steel door
- Trench-style Low Roof with lowered center section for optimal packaging of over cab equipment
- One-piece roped-in windshield
- Optional single or high-visibility three-piece rear window

INTERIOR TRIM LEVELS

- X-Series Base
 - Mordura cloth seat
 - Vinyl sleeper upholstery
 - Standard insulation
 - Standard LED cab lighting
 - Black finish steering wheel switches
 - Black finish dash gauge bezels
 - Carbon with black trim accents
- X-Series Premium
 - Laredo leather seats
 - Upgraded sleeper upholstery
 - Premium insulation
 - Premium LED cab lighting
 - Bright finish steering wheel switches
 - Bright finish dash gauge bezels
 - Premium teak trim

INTERIOR COLORS

- Quarry Grey
- Charcoal Black
- Timber Brown
(available on Premium Package only)

HOOD

- Impact-resistant, durable, lightweight molded resin hood with sloped high-visibility design
- ISO Tech Hood Suspension System
- Standard with locking hood strut

GRILLE

- Radiator-mounted steel grille with stainless steel surround

HVAC

- Best-in-class HVAC with 5 face outlets, 4 floor outlets, 2 side window defrost outlets and 10 blower speeds
- Available only on sleepers, optional Idle-Free Dual HVAC that provides up to 10 hours of cooling or 34 hours of heating when parked

AIR INTAKE

- Engine-mounted air intake, plus optional hood-mounted pre-cleaner deliver improved dust capacity

ENGINE

- Detroit® DD13® Gen 5, 370-525 HP, 1,250-1,850 lb-ft
- Cummins L9, 260-380 HP, 860-1,250 lb-ft
- Cummins X12, 350-500 HP, 1450-1700 lb-ft

TRANSMISSION

- Detroit® DT12®-V AMT
- Allison 3000 and 4000 Series Automatics
- Eaton Fuller 10- 13- 18-speed; 8LL and 9ALL Manuals
- Eaton Ultrashift PLUS and Endurant AMT

POWER TAKE-OFFS (PTOs)

- Intuitive and simple to use PTO control system that makes programming easy
- FEPTO and REPTO available
- Factory installed transmission PTO

STEER AXLE

- Detroit® single 12,000-23,000 lbs
- Meritor single 12,000-22,000 lbs
- Detroit® twin steer tandem 40,000 lbs

REAR DRIVE AXLE

- Detroit® single 23,000 lbs
- Detroit® tandem 40,000-46,000 lbs
- Dana tandem 46,000-50,000 lbs
- Meritor single 21,000-30,000 lbs
- Meritor tandem 40,000-58,000 lbs
- Meritor tridem 69,000-78,000 lbs

PUSHER AND TAG AXLES

- Steer and non-steer 8,000-25,000 lbs

FRONT SUSPENSION

- Flatleaf 14,600-23,000 lbs
- Flatleaf (Tandem) 40,000 lbs
- Taperleaf 12,000-20,000 lbs
- Taperleaf (Tandem) 40,000 lbs

REAR SUSPENSION

- AirLiner® single 21,000-23,000 lbs
- AirLiner® tandem 40,000- 46,000 lbs
- AirLiner® tridem 69,000 lbs
- Chalmers tandem 40,000-70,000 lbs
- Flatleaf single 23,000-30,000 lbs
- Hendrickson tandem 40,000-70,000 lbs
- Neway single 26,000 lbs
- Neway tandem 46,000-52,000 lbs
- Neway tridem 69,000-78,000 lbs
- TufTrac tandem 40,000-52,000 lbs

BRAKES

- WABCO® 4S/4M and 6S/6M Anti-lock Braking System (ABS) with and without traction enhancement
- Air Disc Brakes

ACTIVE SAFETY

- Detroit Assurance® suite of safety systems including: Active Brake Assist 5, Adaptive Cruise Control to 0 MPH, Side Guard Assist, Tailgate Warning, Lane Departure Warning, Automatic Headlights/Wipers and Intelligent High Beams, Brake Hold Mode, Traffic Sign Display and Active Speed Intervention, available with Detroit® engines
- WABCO® OnGuard including collision mitigation and adaptive cruise control, optional with Cummins engines

FRAME

- Single-channel RBM @ 1.8-3.8MM inch-lbs
- Inner C-channel reinforced RBM @ 4.4-5.5MM inch-lbs
- 8"-30" parent rail front frame extensions options available

BUMPERS

47X offers three bumper styles in various finishes and thicknesses, as well as boxed-in bumper with an optional grille guard for logging applications. All 47X bumpers are tapered at the wheel ends for ground clearance and weight savings

- Standard 1/8" stainless steel vocational
- Optional 3/16" painted steel
- Optional 1/4" plain or polished aluminum
- Optional 5/16" bright steel severe service
- Optional 3/8" painted steel severe service
- Optional 1/4" painted or bright steel logger

FRONT TOW DEVICES

- There are a number of towing device options mounted directly to the front frame head for increased strength and durability, with ratings from 80,000-140,000 lbs
- Dual Removable Tow Hoops, 80,000 lbs
- Center Tow Pin, 80,000 lbs
- High Capacity Center Tow Pin, 140,000 lbs

FUEL TANKS

- Aluminum 25" cylindrical, plain or polished
- LH 60-150 gallon (227-568 liter)
- LH 60, 80 and 90 gallon rectangular tanks
 - Optional raised fuel tank mounting
- RH 60-, 70-, 80-, 100-, 120-, 150-gallon (227-, 265-, 303-, 379-, 454-, 569-liter)
- Standard forward mounting; optional aft mounting
- LH and RH split fuel/hydraulic tank options available
- LH and/or RH auxiliary fuel supply and return ports available

DEF TANK

- 8-, 13- and 23-gallon (23-, 49- and 87-liter)
- Standard forward mounting
- Optional LH or RH aft mounting

UPFIT EFFICIENCY FEATURES

- All-new QuickFit Interface System
 - Easier to integrate truck equipment with the vehicle's electrical power and communication sources
 - Advanced multiplexed electrical system for easy Truck Equipment Manufacturer (TEM) interface, programming and power access
 - Auxiliary in-cab backwall mounted E-Vault available, which houses:
 - QuickFit Programmable Modules
 - QuickFit Programmable Interface Connector
 - TEM-specific power distribution module
 - High-current power access
- Multiple clear back-of-cab chassis configurations

- Updated standard air dryer mounting location delivers clear back-of-cab
- Standard in-cab battery mounting location with optional mounting on frame or between rails
- Up to 24 programmable multiplexed, 4 hard-wired and 2 pneumatic switches

All 47X technical details can be found in the Western Star Technical Resource Guide (TRG). For access to the TRG, log on to DTNACconnect.com



**HAND BUILT
IN THE USA**

Cleveland, NC Portland, OR

DAIMLER | Western Star - A Daimler Group Brand

WS/MC-DT-615. Specifications are subject to change without notice. Western Star Truck Sales, Inc. is registered to ISO 9001:2015 and ISO 14001:2015. Copyright © 2021 Daimler Trucks North America LLC. All rights reserved. Western Star Truck Sales, Inc. is a subsidiary of Daimler Trucks North America LLC, a Daimler company. For the Western Star dealer nearest you, call 1-866-850-STAR | WESTERNSTAR.COM