

LDT2

Low Entry
Drop Frame Tilt



Base Model Specifications

FEATURES

New Cab Design - Interior and Exterior

Roomier Interior - 5 1/2 in. Deeper Cab

New Ergonomic Dash

Simplified "Multi-Plex" Instruments

Improved "HVAC" System and Controls

Sealed Integrated Switches

Heavy Duty, Welded Drop Section
Frame, 10" Fabricated

Low Entry on Both Sides

Dual Steering with R.H. Bi-Fold Door

Remote Mounted Radiator

Single or Tandem Axles



CRANE CARRIER COMPANY

GENERAL INFORMATION

GENERAL DATA

POWER SYSTEM

ENGINE	*Cummins ISC03-260
• Horsepower/Torque, ft. lbs.	260/800
• Governed Speed, r.p.m.	2,200
• Lube Oil Filter, Spin-on Type	Full Flow
• Air Compressor, CFM	18.7
• Automatic Shutdown, sec.	30
TRANSMISSION, model	*Allison 3500RDS
• Gearing	5 Forward, 1 Rev.
• Oil Cooler in Tank	Oil to Water
RADIATOR	
• Frontal Area, sq. in.	1,200
• Core	3 Row
• Location	Remote Behind Cab
PROPELLER SHAFT, series	Spicer, SPL 140
AIR CLEANER, Intake above cab	L.H., Donaldson 15" FRG
EXHAUST, Mounted above frame	L.H., Vertical
FUEL TANK	
• Capacity, Rectangular Steel, Gal.	50
• Mounting	L.H. Wittke & McNeilus, R.H. Other

FRAME

MAIN, size, in.	10 x 3 x .38
LINER, size, in.	.9 x 2.62 x .31
• Yield strength, psi	50,000 & 80,000
• Section Modulus	
Straight Section, in ³	23.10
At Drop Section, in ³	57.68
• RBM	
Straight Section, in-lbs per rail	1,848,000
At Drop Section, in-lbs per rail	3,461,000
LENGTH, ft. - in.	26-6 to 30-10
CROSSMEMBERS, construction	Tubular
BUMPER, Steel channel, in.	15.75
GROUND CLEARANCE, in.	21
TOW PINS, Front, through bumper	2

AXLES - SUSPENSIONS

FRONT AXLE, model	*DANA, EFA-20F4
• Capacity, lbs.	20,000
• Wheel cut, degrees	46
FRONT SUSPENSION	CCC
• Capacity, At ground, lbs.	17,000
• Springs, Tapered leaf, size, in.	4 x 50
• Shock Absorbers, bore, in.	1.62

SINGLE REAR AXLE

• Axle, model	*DANA, 26105S
Capacity, lbs.	26,000
• Suspension, model	*REYCO, 102CC
Capacity, lbs.	26,000

TANDEM REAR AXLE

• Axle, model	*DANA, DS405P
Capacity, lbs.	40,000
• Suspension, model	*HENDRICKSON, HN402
Capacity, lbs.	40,000

BRAKES

FRONT, S-CAM, in.	16.5 x 6
REAR, S-CAM, in.	16.5 x 7
DRUMS	Cast Iron
PARKING BRAKES	Spring Loaded
SLACK ADJUSTERS	Bendix, Auto
ABS System	Eaton-Bosch, 4-Channel
RESERVOIR CAPACITY (Steel), cu. in.	6,360

TIRES & WHEELS

FRONT TIRES, Highway tread, size	315/80R22.5 - 20 Ply
REAR TIRES, Highway tread, size	11R22.5 - 16 Ply
WHEELS, Front and Rear	Steel Disc, Hub Pilot
• Front dia. x width, in.	22.5 x 9.00
• Rear dia. x width, in.	22.5 x 8.25

STEERING

POWER STEERING GEAR, model	Sheppard 592S
CAPACITY, lbs.	20,000
HYDRAULIC PUMP	Coupling Driven
RESERVOIR CAPACITY, qts.	16

ELECTRICAL

SYSTEM, type, voltage	Negative Ground, 12V
ALTERNATOR, Delco 21SI, amps	*160
STARTER, Delco 42MT	Type 400
BATTERIES, 2 Grp. 31 MF, Total CCA	1,850
BATTERY CABLES, Dual path, size	0000
BACK UP ALARM	107dB(A)

PAINT

CAB INTERIOR & EXTERIOR,	
Acrylic Polyurethane	CCC White
FRAME, FENDERS, EXHAUST, AIR INTAKE &	
ENGINE COVER, Polyurethane	Gloss Black
BUMPER & WHEELS, Polyurethane	Light Gray

STANDARD EQUIPMENT

CAB

LOW ENTRY - TILT CAB
18" FLOOR HEIGHT BOTH SIDES
60" HYDRAULIC TILT
AUTOMATIC LOCK & LATCH
WINDSHIELD AREA 2,600 Sq. In.
SUNVISORS, PADDED W/MAP HOLDERS
GALVANEAL STEEL PANELS
40,000 BTU HEATER/DEFROSTER
18" DIA. TILT/TELESCOPIC, PADDED STEERING WHEEL
DRIVER'S SEAT, 4-WAY ADJUSTABLE
PASSENGER SEAT, FLIP UP/DOWN
RETRACTABLE SEAT BELTS W/HEIGHT ADJ.
SHOULDER HARNESS
DUAL ELECTRIC WINDSHIELD WIPERS W/WASHERS
ELECTRIC HORN
RIGID URETHANE R9 INSULATION
TWO ROOF VENTS
TWO 16" X 7" STAINLESS STEEL WEST COAST MIRRORS
COMBO MIRRORS, 6.5 X 10 FLAT & 6.5 X 6 CONVEX, R.H.
ASH TRAY & CIGAR LIGHTER
ANTI-SPRAY FENDER BRUSHES
LEFT STEEL DOOR OPENS 90°, ROLL-DOWN WINDOW
RIGHT STEEL BI-FOLD DOOR, SLIDING WINDOW
LOWER VIEW WINDOWS IN DOORS
ARMREST ON STANDARD DRIVER'S DOOR
OVERHEAD CONSOLE W/STORAGE, FULL WIDTH
MOLDED DASH & TRAY
SHIFT CONSOLE W/TWO DRINK CUP HOLDERS
PASS-THROUGH CABIN
INNER FENDER SPLASH SHIELDS

INSTRUMENTS

ELECTRIC SPEEDOMETER, TWO TRIP ODOMETERS,	
STOP WATCH & ELECTRICAL GAUGES FOR:	
• FUEL LEVEL	• COOLANT TEMPERATURE
• OIL PRESSURE	• VOLTMETER
• TACHOMETER	• ENGINE HOURMETER
AIR RESTRICTION INDICATOR MOUNTED ON AIR FILTER	
DUAL AIR PRESSURE GAUGE	
WARNING ALARM AND LIGHTS FOR:	
• LOW AIR PRESSURE GAUGE	
• HIGH COOLANT TEMPERATURE GAUGE	
• LOW COOLANT LEVEL	
WARNING LIGHT FOR:	
• PARKING BRAKE ON	

- TRANSMISSION OIL TEMPERATURE
- TANDEM AXLE INTERLOCK ENGAGED
- FUEL LEVEL GAUGE
- ENGINE CHECK & PREHEAT
- ABS SYSTEM
- TRANSMISSION IN NEUTRAL

ELECTRICAL & LIGHTING

FIVE AMBER CLEARANCE LIGHTS	
FRONT TURN SIGNALS BEHIND BUMPER	
DOME LIGHT W/MAP LIGHTS IN CAB	
DIMMER SWITCH ON STEERING COLUMNS	
SELF-CANCELLING TURN SIGNAL SWITCHES	
SIGNAL BUZZER FOR BODY	
TWO-WAY RADIO POWER FEED	
TWO SWITCHES IN CAB WIRED TO OUTSIDE J-BOX	
LARGE, SINGLE RECTANGULAR HALOGEN HEADLIGHTS	
PLUG-IN RELAYS, BUZZERS AND FLASHER UNIT	
AUTOMATIC RESET CIRCUIT BREAKERS	
SEPARATE CIRCUIT BREAKERS FOR:	
• STOP LIGHTS	• TAIL LIGHTS
• BACK UP LIGHTS	• TURN SIGNALS
• CLEARANCE LIGHTS	

RIGHT SIDE AUXILIARY STEERING

18" TILT/TELESCOPIC, PADDED STEERING WHEEL W/HORN	
FLIP SEAT FOR STAND-UP DRIVE	
RETRACTABLE SEAT & DOOR OPENING BELTS	
WINDSHIELD WIPER CONTROLS	
ACCELERATOR & BRAKE FOOT CONTROLS	
SPEEDOMETER	
ENGINE START & STOP SWITCHES	
TURN SIGNAL SWITCH	
HEADLIGHT SWITCH	
GAUGES, ANSI COMPLIANCE	
HIGH BEAM CONTROL	
FLOOR GRATING	
DUAL AIR PRESSURE GAUGE	
INDICATOR LIGHTS FOR:	
• TRANSMISSION IN NEUTRAL	
• TURN SIGNALS	• PARK BRAKE ON

MISCELLANEOUS

SUSPENSION TORQUE RODS
STEMCO OIL SEALS - ALL AXLES
PUSHBUTTON TRANSMISSION CONTROLS

*Optional components available. Specifications subject to change without notice.

OPTIONAL COMPONENTS

POWER SYSTEM

(VARIOUS HORSEPOWER)

- CUMMINSISL03, ISM02
- CATERPILLARC7, C9, C11
- ENGINE BRAKES

TRANSMISSIONS

AUTOMATIC - ALLISON

- MD3060P, MD3066P, 3000, 4000 & 4500
- RETARDERS

FRONT AXLES

- MERITOR FL94120,000 lb.

FRONT SUSPENSIONS

- PARABOLIC TAPER LEAF20,000 lb.
- MULTI-LEAF23,000 lb.

REAR AXLES

SINGLE

- DANA26,000 to 30,000 lb.
- MERITOR26,000 to 30,000 lb.

TANDEM

- DANA40,000 to 46,000 lb.
- MERITOR40,000 to 46,000 lb.

REAR SUSPENSIONS

SINGLE

- REYCO, Three Torque Rod30,000 lb.
- RIDEWELL, RED22830,000 lb.
- AIR LIFT TAG

TANDEM

- HENDRICKSON, RS & RT240,000 to 46,000 lb.
- HENDRICKSON, HN46,000 lb.
- RIDEWELL40,000 to 46,000 lb.
- AIR RIDE46,000 lb.

MISCELLANEOUS OPTIONS

- AIR CONDITIONING
- AIR DRYERS
- AIR HORN
- AIR RIDE SEATS
- ALCOHOL INJECTOR
- ATC - AUTOMATIC TRACTION CONTROL
- AUTOMATIC DRAIN VALVES
- BATTERY DISCONNECT
- BI-FOLD DOOR, LH
- BLOCK HEATERS
- CCC AUTO NEUTRAL W/WORK BRAKE
- CAST SPOKE WHEELS, FRONT & REAR
- CREW CAB (3, 4 AND 5 PERSON)
- DISC ALUMINUM WHEELS, FRONT & REAR
- FANS, OVERHEAD CONSOLE MOUNTED
- FIXED STEERING COLUMNS
- FUEL/WATER SEPARATOR
- HEATED MIRRORS
- SIT-DOWN RH DRIVE
- VARIOUS TIRES, SIZES, AND TREADS

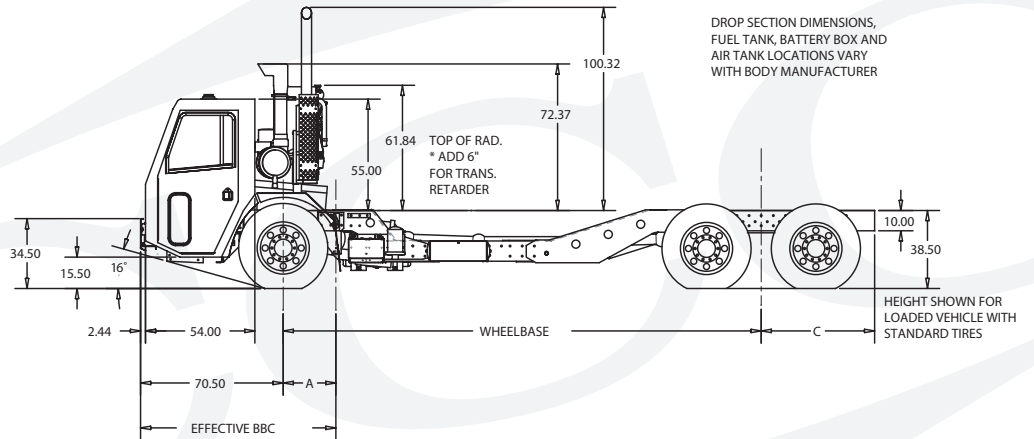
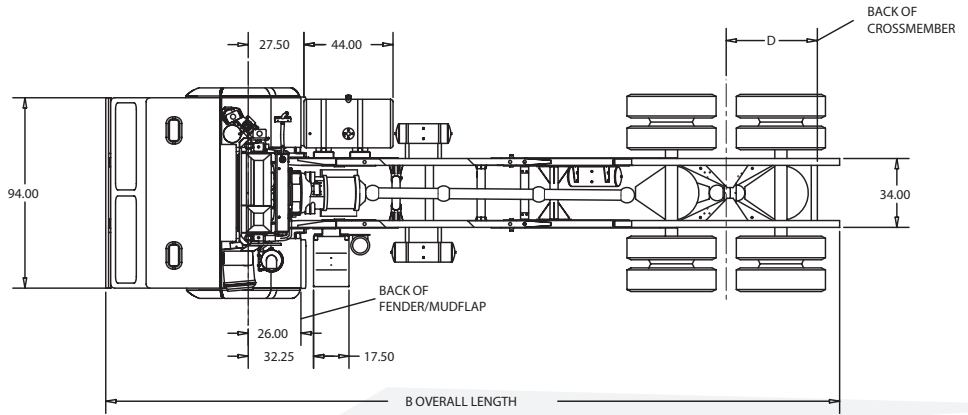

BODY MFR.	REAR AXLE	WHEEL BASE	A		B OVERALL LENGTH	C A/F	D BACK OF X-MEMBER
			SC03,C7, ISL03,C9	ISM02, C11			
McNeilus	Single	212.00	20.00	26.00	311.63	29.13	29.00
E-Z Pack	Single	224.00	20.00	n/a	331.50	37.00	33.00
Labrie	Single	224.00	20.00	n/a	344.50	50.00	33.00
E-Z Pack	Single	230.00	20.00	26.00	345.50	45.00	33.00
Labrie	Single	230.00	20.00	26.00	350.50	50.00	33.00
Wittke	Single	231.00	20.00	26.00	350.50	49.00	33.00
McNeilus	Single / Tag	212.00	20.00	26.00	372.50	90.00	33.00
E-Z Pack	Single / Tag	224.00	20.00	n/a	384.50	90.00	33.00
Labrie	Single / Tag	224.00	20.00	n/a	384.50	90.00	33.00
E-Z Pack	Single / Tag	230.00	20.00	26.00	390.50	90.00	33.00
Labrie	Single / Tag	230.00	20.00	26.00	390.50	90.00	33.00
Wittke	Single / Tag	231.00	20.00	26.00	391.50	90.00	33.00
Wittke	Tandem	231.00	20.00	26.00	350.50	49.00	45.00
Labrie	Tandem	236.00	20.00	26.00	362.50	56.00	45.00
McNeilus	Tandem	238.00	20.00	26.00	360.50	52.00	45.00
E-Z Pack	Tandem	248.00	20.00	26.00	383.50	65.00	45.00

Distributed by



CRANE CARRIER COMPANY
The Refuse Vehicle Specialists